

Big Data Analytics, Deep learning, Explainable AI
(XAI)

Big data

- Big data refers to data sets that are too large or complex to be dealt with by traditional data-processing application software.
- Data with many fields offer greater statistical power, while data with higher complexity may lead to a higher false discovery rate.

Type of Data

- **Structured**
 - Tables
- **Semi-Structured**
 - XML, JSON
 - Clickstream data, Ecommerce, APIs
- **Unstructured**
 - Audio, Video, Images, Text, Sensory Data
 - IoT Devices, Social Media

Data

- Storage
 - SQL, NoSQL
- Processing
 - Hadoop

Dimensions of big data

- Volume
- Velocity
- Variety
- Veracity
- Variability
- Complexity
- Value
- Decay

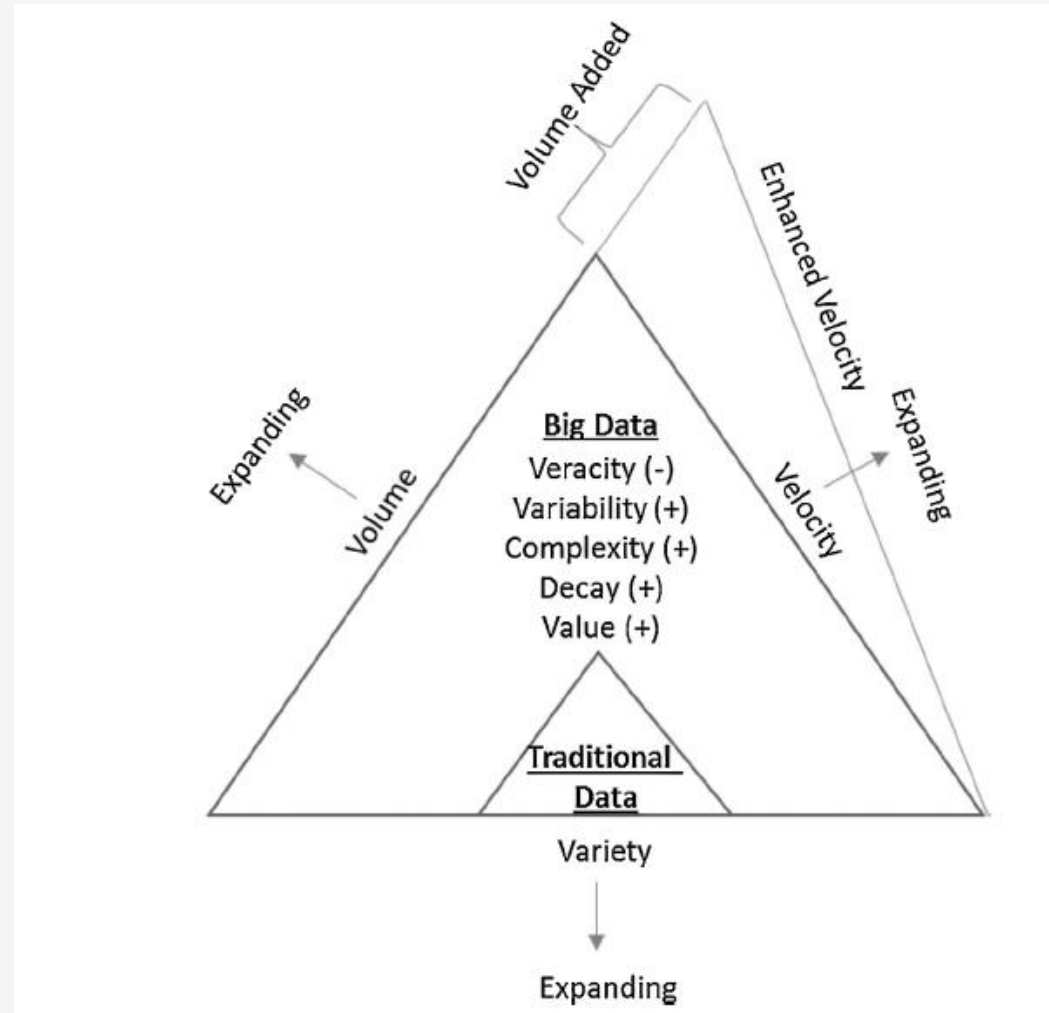

Evolution of big data and data analytics

- 1950s to mid-1990s
- Big Data 1.0
- Big Data 2.0
- Big Data 3.0

Big Data 1.0

- Web usage mining
- Web structure mining
- Web content mining

Web content mining

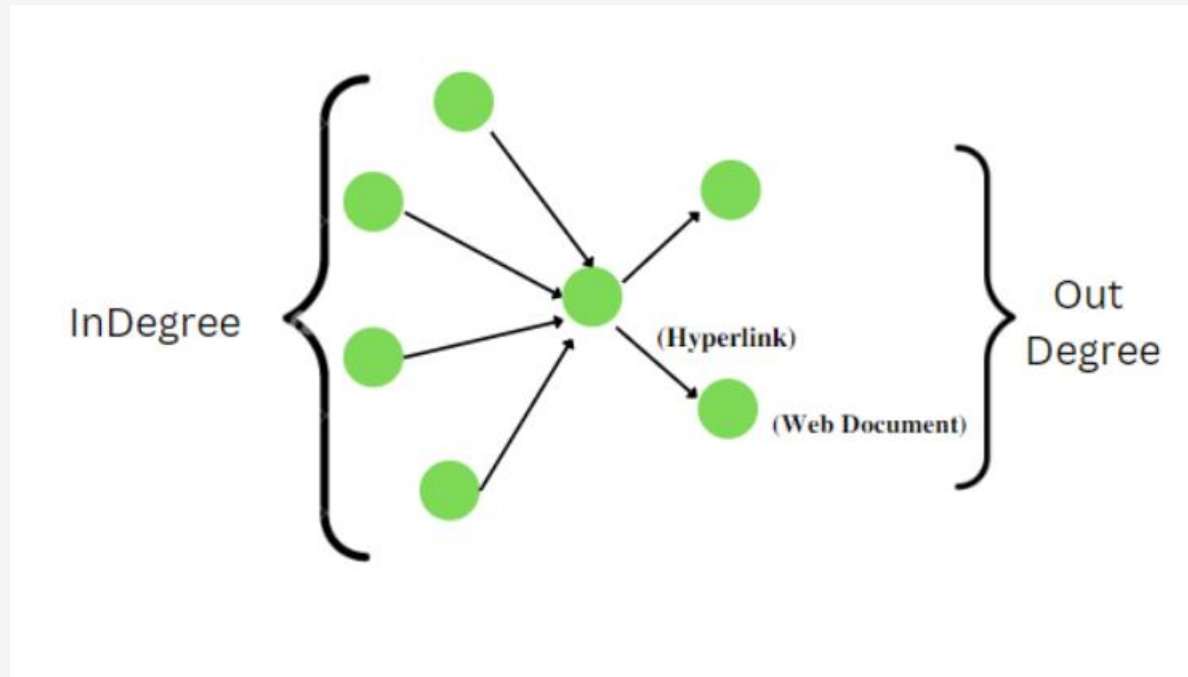

Big Data 2.0

- Social Media
 - Sentiment Analysis
 - Entity, sentence, document level
 - Lexicon-based, Machine Learning
 - Social Network Analysis
 - network structure, connections, nodes,
 - network density, network centrality, network flows

Big Data 3.0

- IoT Applications
 - Streaming Analytics
 - Edge Computing

Neural Networks

A neural network is a series of algorithms that endeavors to recognize underlying relationships in a set of data through a process that mimics the way the human brain operates.

Neural nets are a means of doing machine learning, in which a computer learns to perform some task by analyzing training examples.

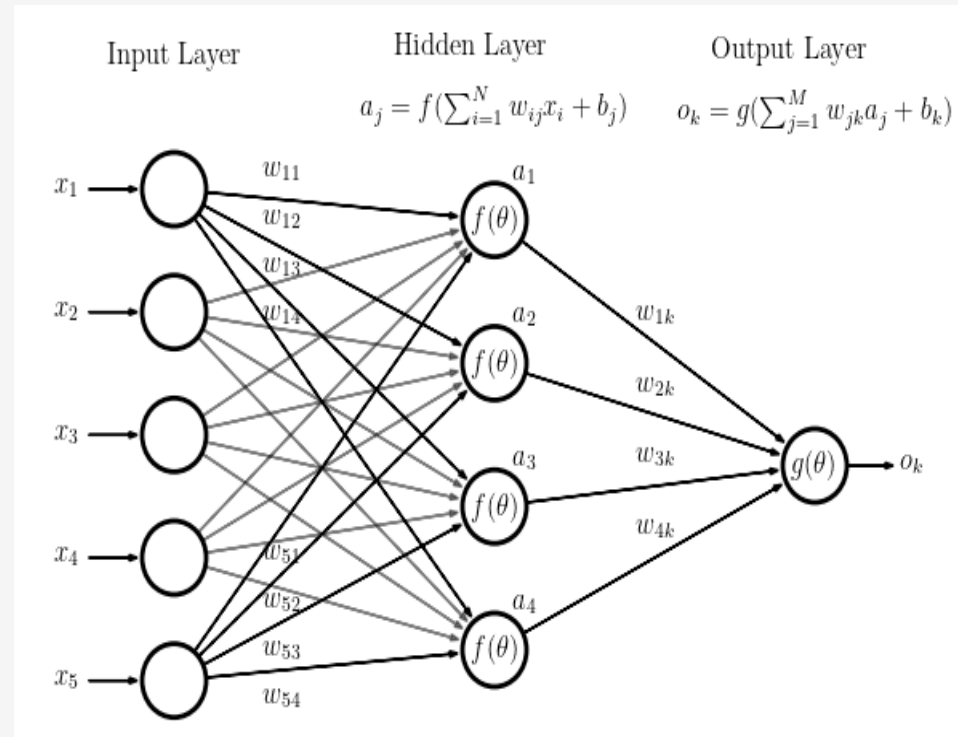

Introduction to Neural Networks

Introduction to Neural Networks

- Handwritten digit recognition (**MNIST dataset**)
 - The intensity of each pixel is considered an **input** element
 - **Output** is the class of the digit

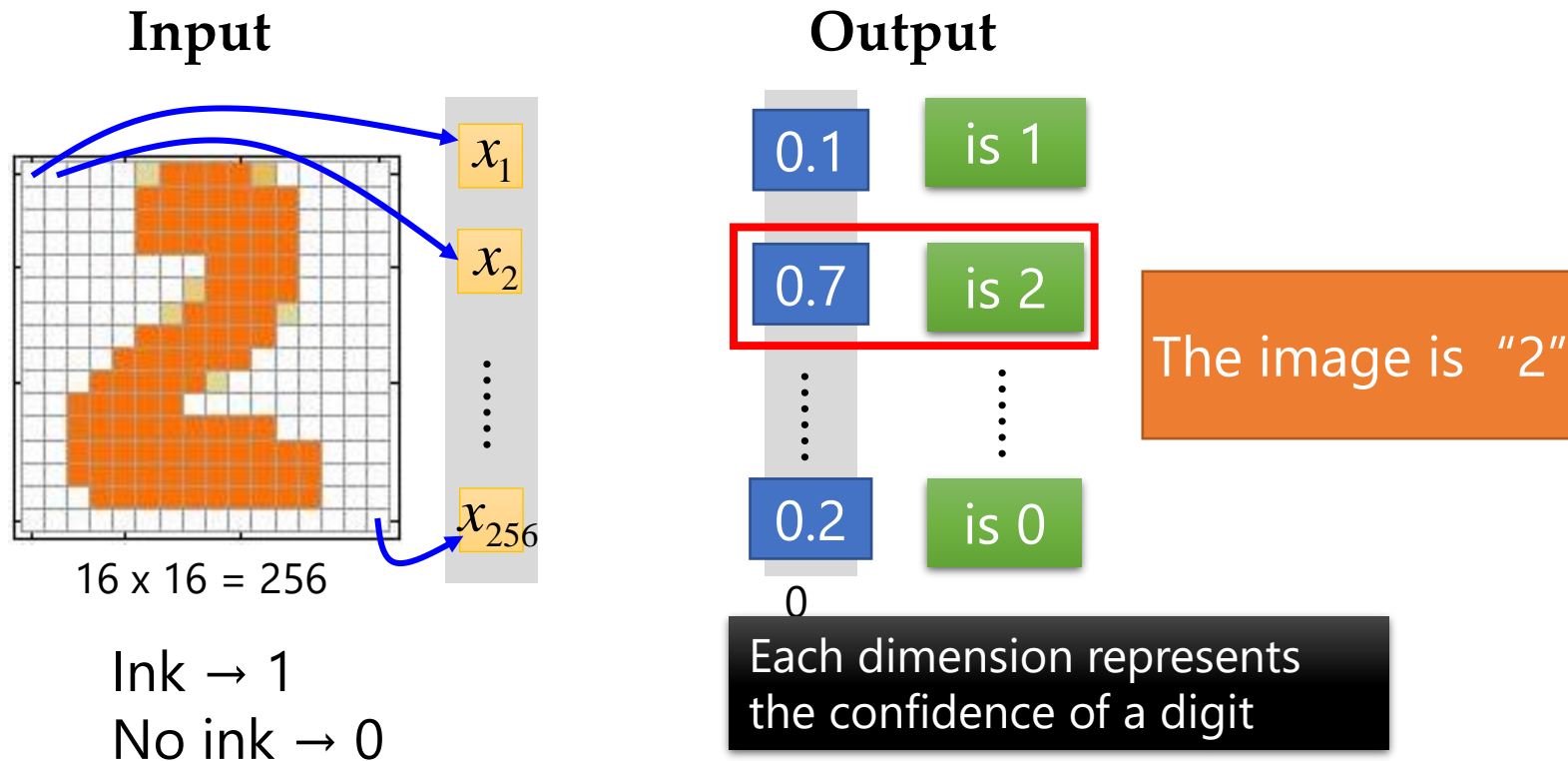

Introduction to Neural Networks

Introduction to Neural Networks

- Handwritten digit recognition

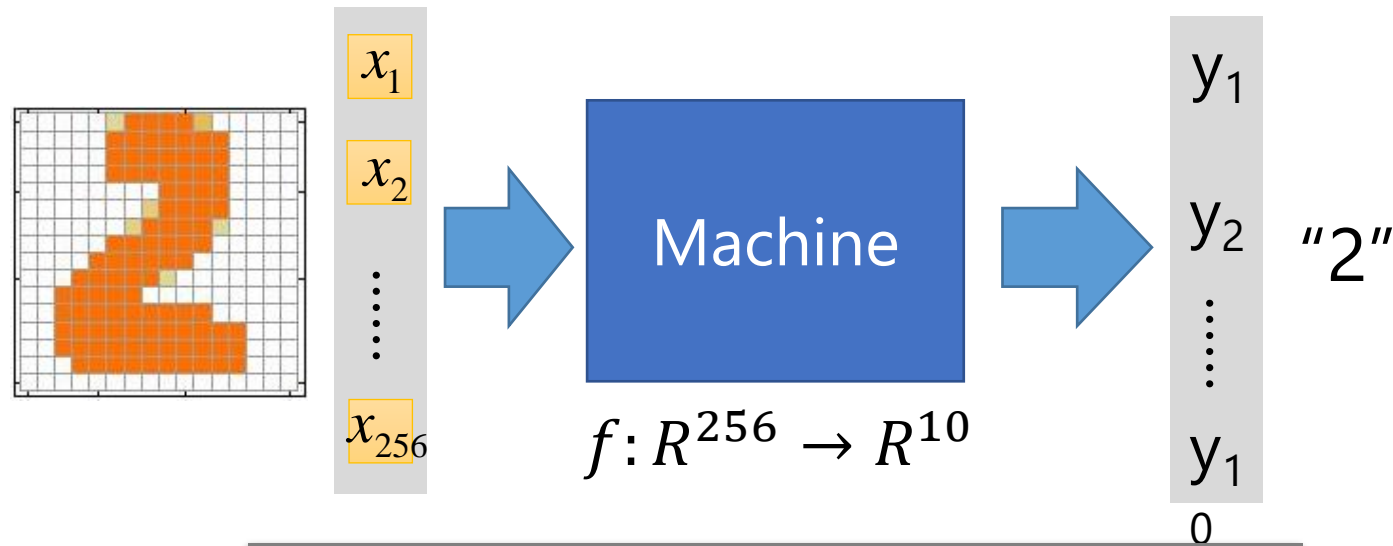

The function f is represented by a neural network

Elements of Neural Networks

Introduction to Neural Networks

- NNs consist of hidden layers with neurons (i.e., computational units)
- A single **neuron** maps a set of inputs into an output number, or $f: R^K \rightarrow R$

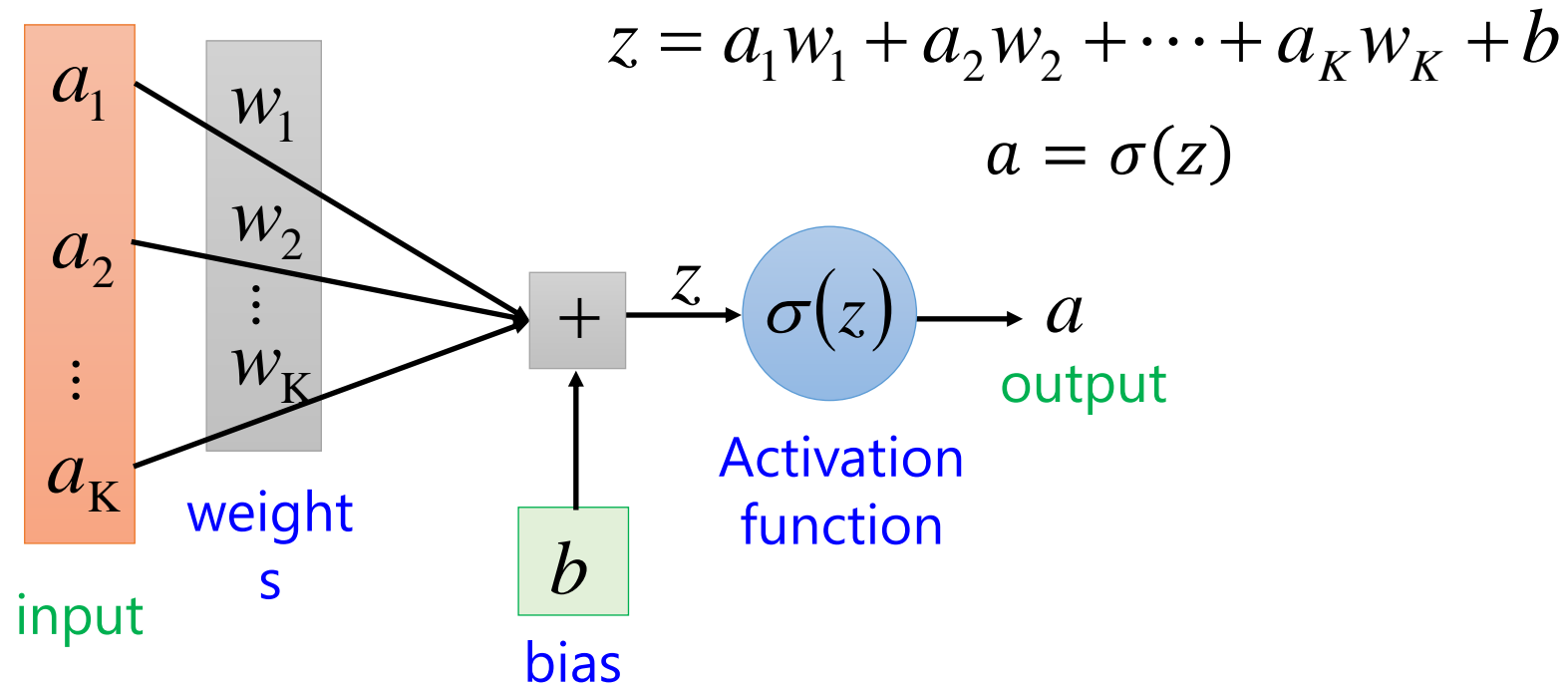

Elements of Neural Networks

Introduction to Neural Networks

- A NN with one hidden layer and one output layer

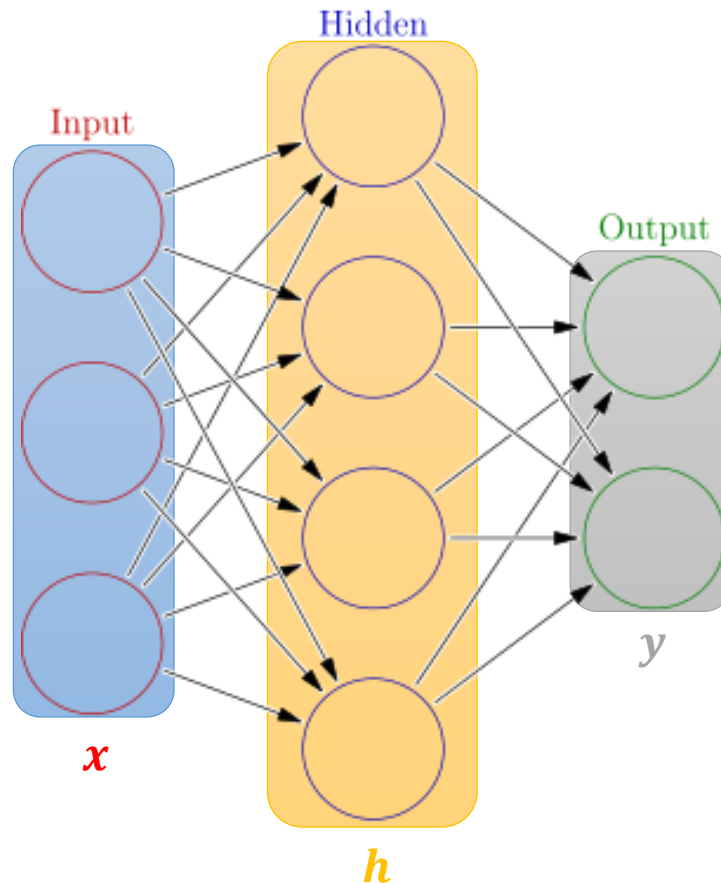

Weights Biases

$$\text{hidden layer } h = \sigma(W_1x + b_1)$$
$$\text{output layer } y = \sigma(W_2h + b_2)$$

Activation functions

Blue arrows point from the labels 'Weights' and 'Biases' to the corresponding terms in the equations. Another blue arrow points from the label 'Activation functions' to the σ function in the second equation.

4 + 2 = 6 neurons (not counting inputs)
[3 × 4] + [4 × 2] = 20 weights
4 + 2 = 6 biases

26 learnable parameters

Elements of Neural Networks

Introduction to Neural Networks

- Deep NNs have many hidden layers
 - **Fully-connected** (**dense**) layers (a.k.a. **Multi-Layer Perceptron** or MLP)
 - Each neuron is connected to all neurons in the succeeding layer

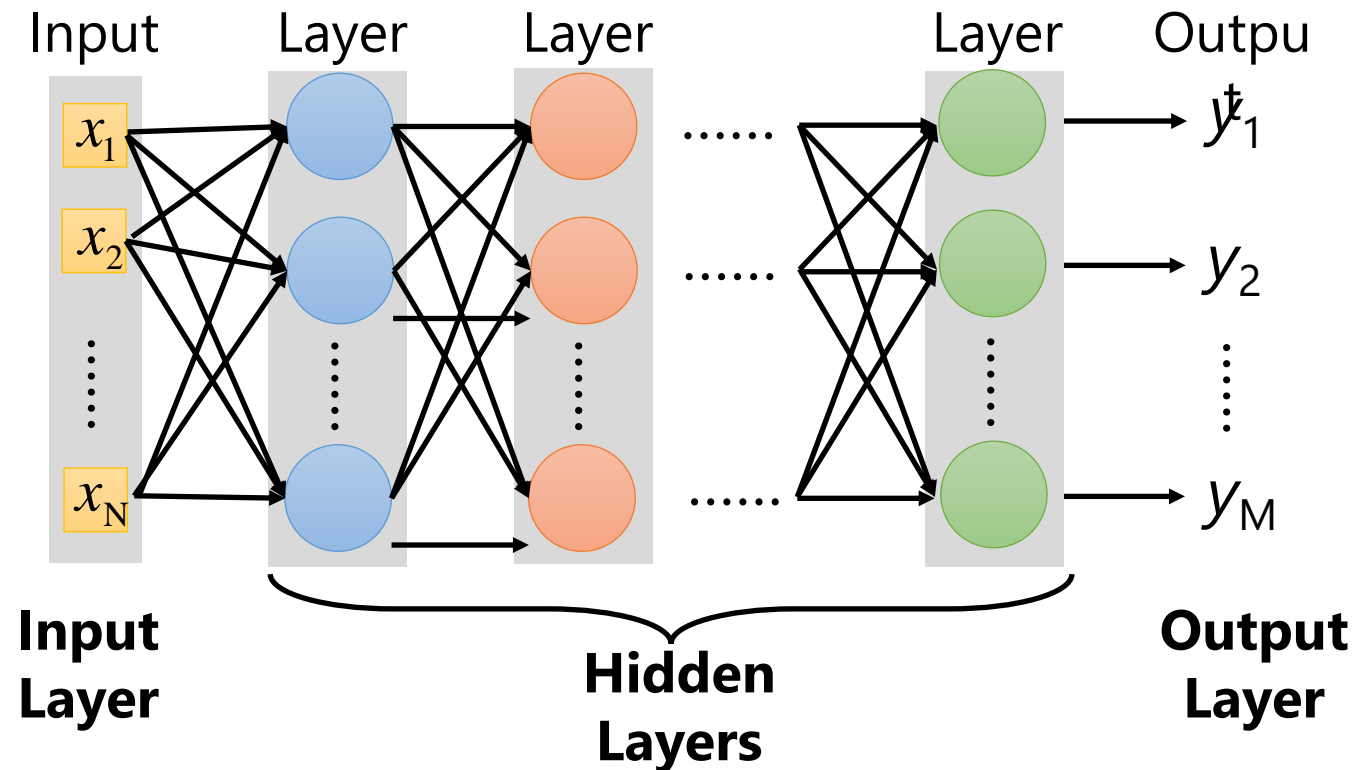

Elements of Neural Networks

Introduction to Neural Networks

- A simple network, toy example

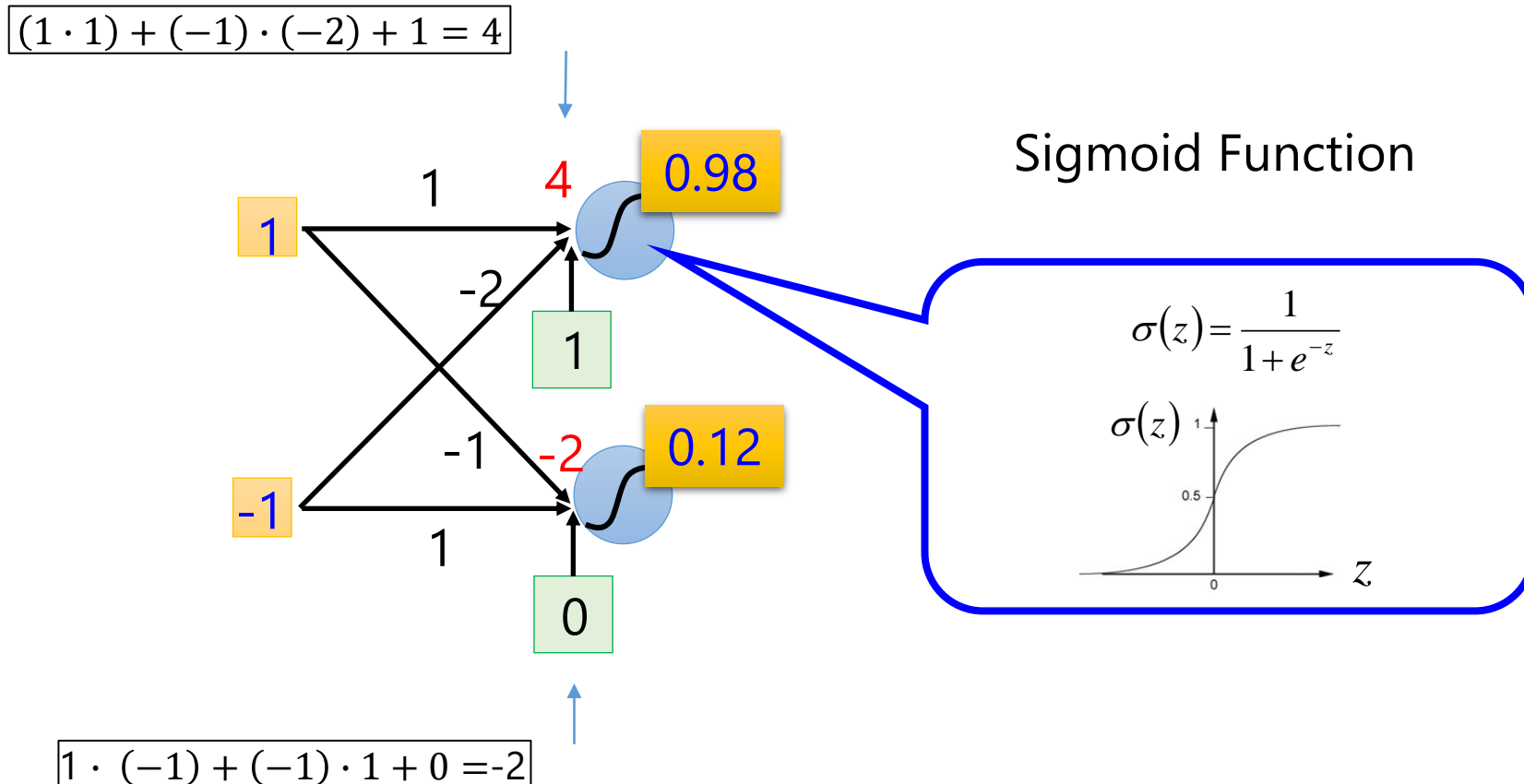

Elements of Neural Networks

Introduction to Neural Networks

- A simple network, toy example (cont'd)
 - For an input vector $[1 \ -1]^T$, the output is $[0.62 \ 0.83]^T$

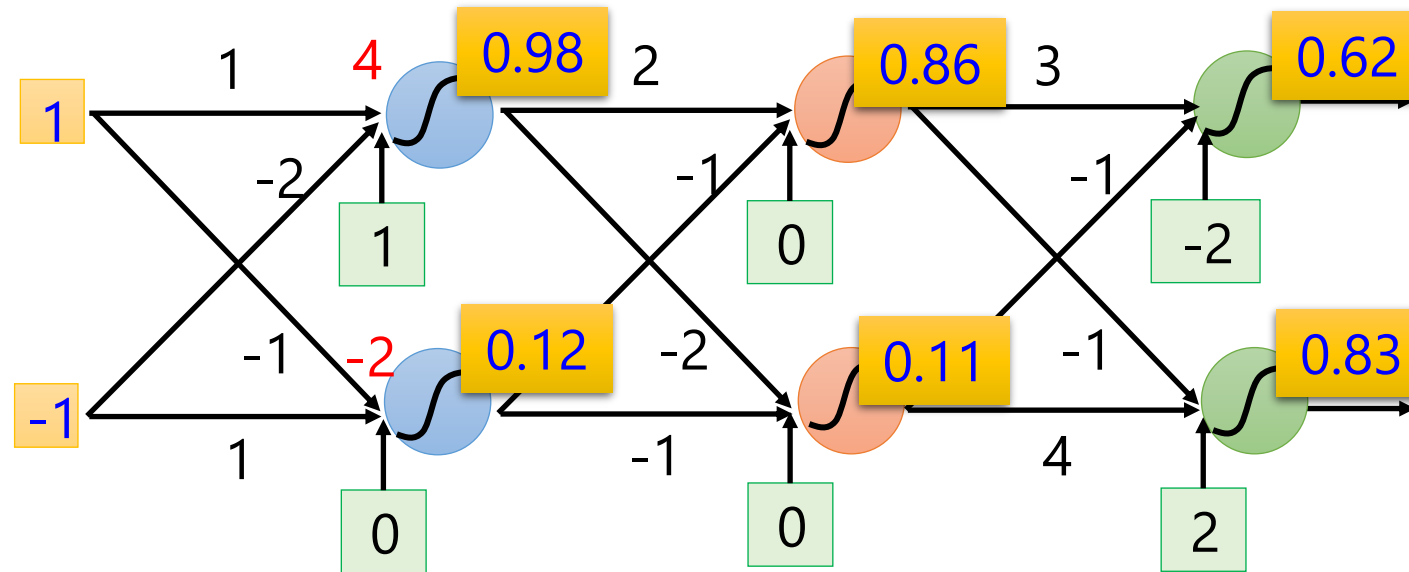

$$f: \mathbb{R}^2 \rightarrow \mathbb{R}^2 \quad f\left(\begin{bmatrix} 1 \\ -1 \end{bmatrix}\right) = \begin{bmatrix} 0.62 \\ 0.83 \end{bmatrix}$$

Matrix Operation

Introduction to Neural Networks

- Matrix operations are helpful when working with multidimensional inputs and outputs

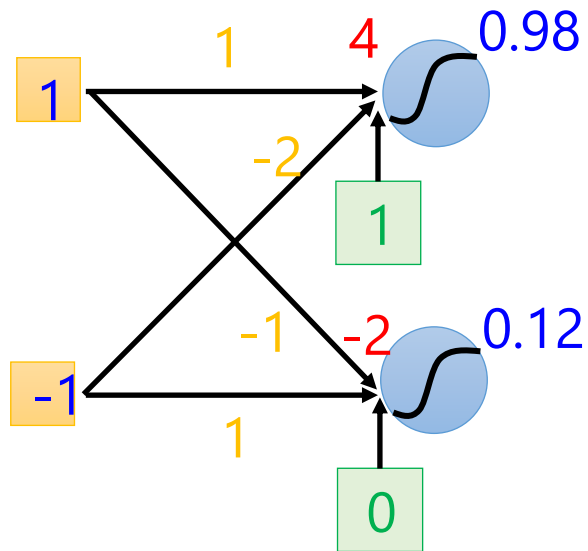

$$\sigma(W x + b) = a$$
$$\sigma(\underbrace{\begin{bmatrix} 1 & -2 \\ -1 & 1 \end{bmatrix} \begin{bmatrix} 1 \\ -1 \end{bmatrix} + \begin{bmatrix} 1 \\ 0 \end{bmatrix}}_{\begin{bmatrix} 4 \\ -2 \end{bmatrix}}) = \begin{bmatrix} 0.98 \\ 0.12 \end{bmatrix}$$

Matrix Operation

Introduction to Neural Networks

- Multilayer NN, matrix calculations for the first layer
 - Input vector x , weights matrix W^1 , bias vector b^1 , output vector a^1

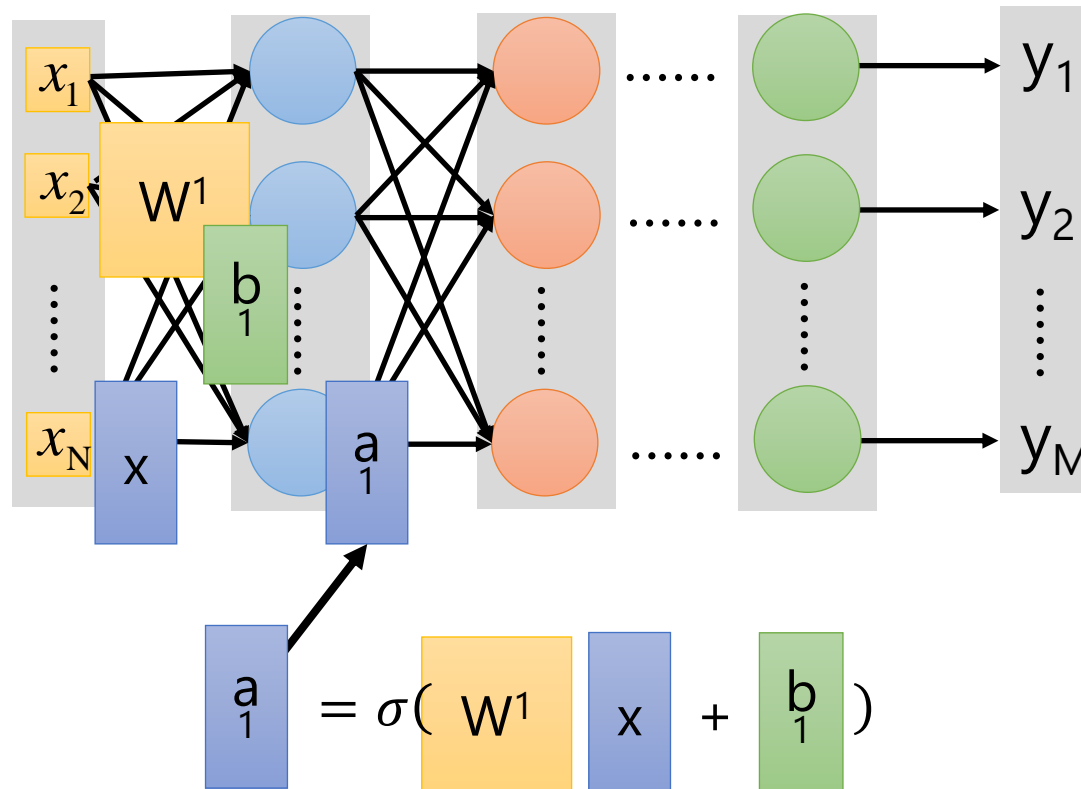

Activation Functions

Introduction to Neural Networks

- **Non-linear activations** are needed to learn complex (non-linear) data representations
 - Otherwise, NNs would be just a linear function (such as $W_1W_2x = Wx$)
 - NNs with large number of layers (and neurons) can approximate more complex functions
 - Figure: more neurons improve representation (but, may overfit)

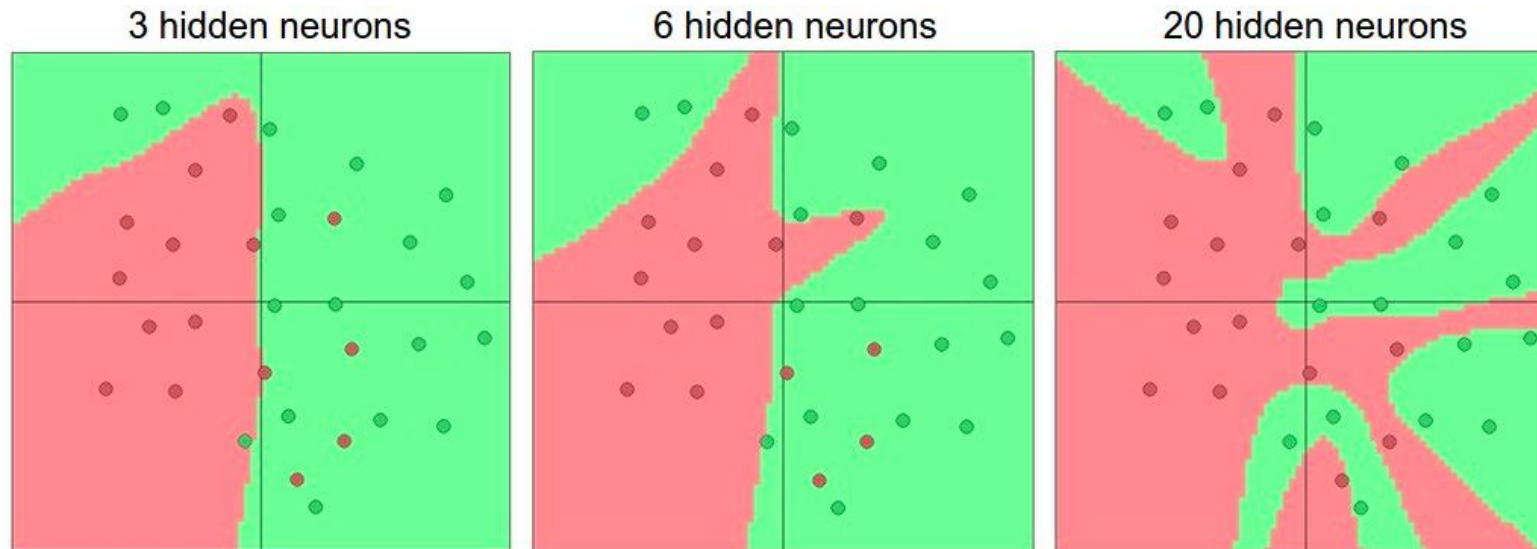

Generalization

Generalization

- **Underfitting**

- The model is too “simple” to represent all the relevant class characteristics
- E.g., model with too few parameters
- Produces high error on the training set and high error on the validation set

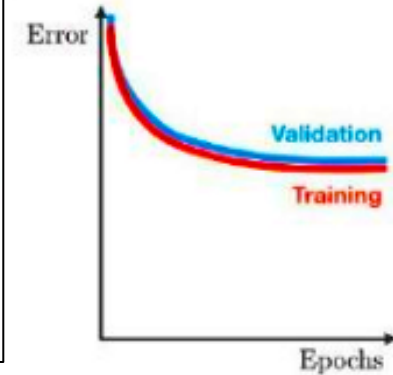
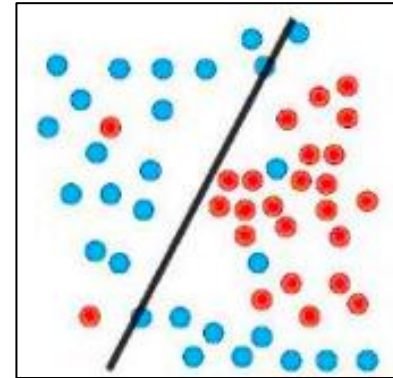

- **Overfitting**

- The model is too “complex” and fits irrelevant characteristics (noise) in the data
- E.g., model with too many parameters
- Produces low error on the training error and high error on the validation set

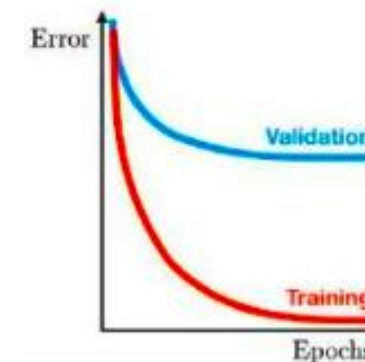
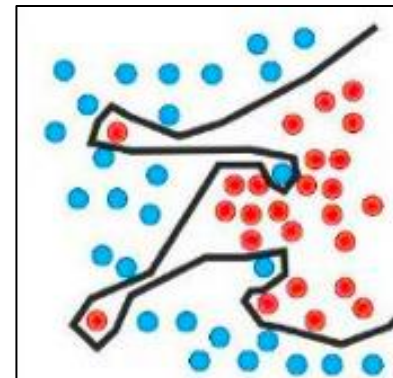

k -Fold Cross-Validation

k-Fold Cross-Validation

- Illustration of a 5-fold cross-validation

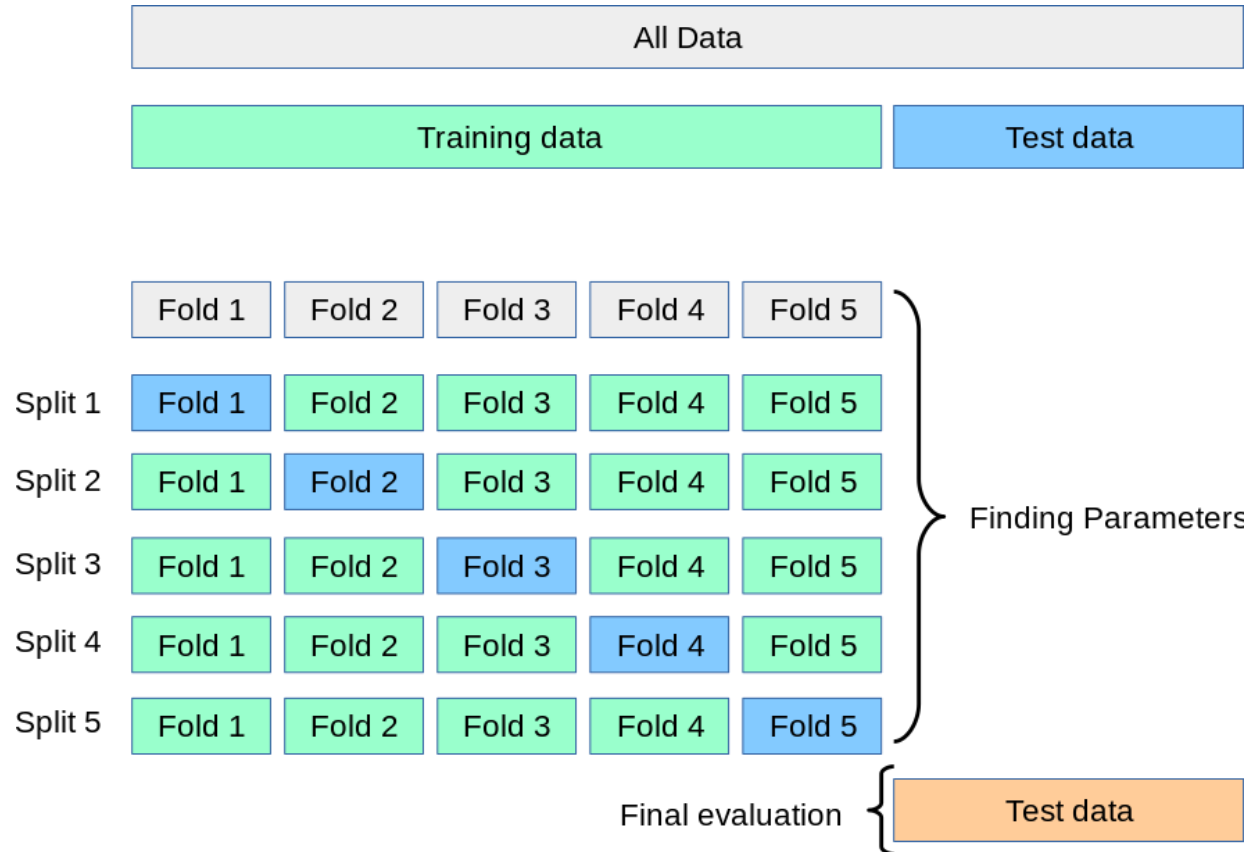

Deep vs Shallow Networks

Deep vs Shallow Networks

- **Deeper networks** perform better than shallow networks
 - But only up to some limit: after a certain number of layers, the performance of deeper networks plateaus

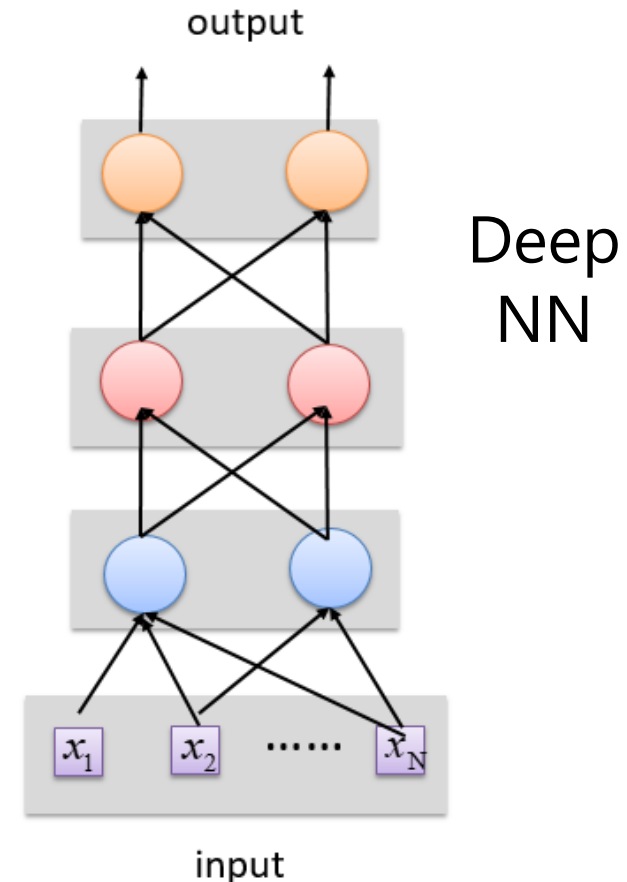
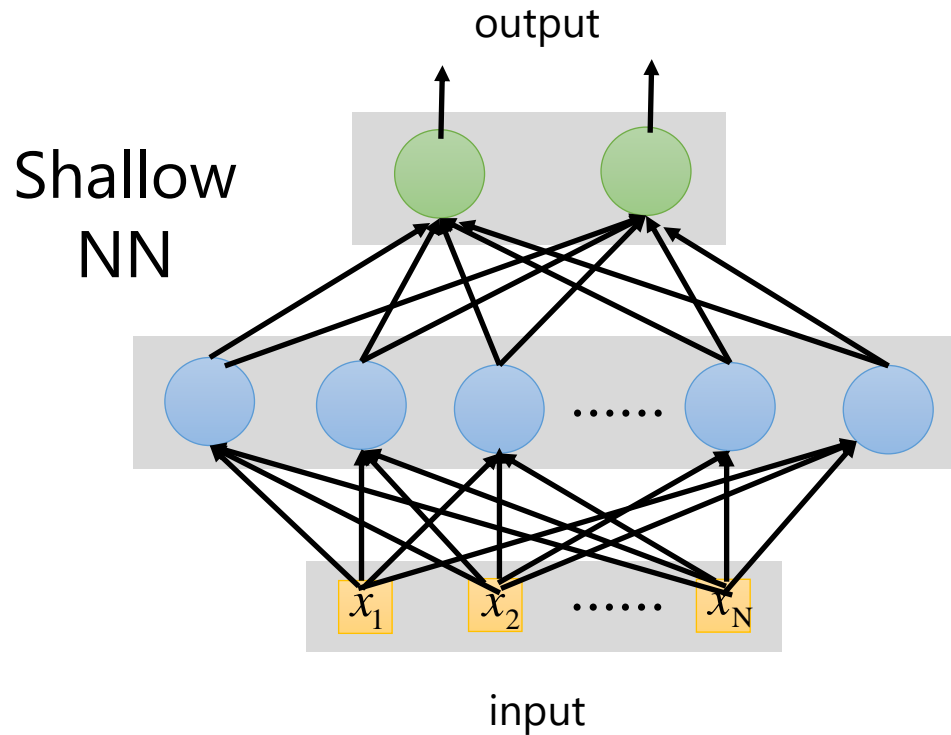



Predicted: **wolf**
True: **wolf**



Predicted: **husky**
True: **husky**



Predicted: **wolf**
True: **wolf**

Incorrect prediction

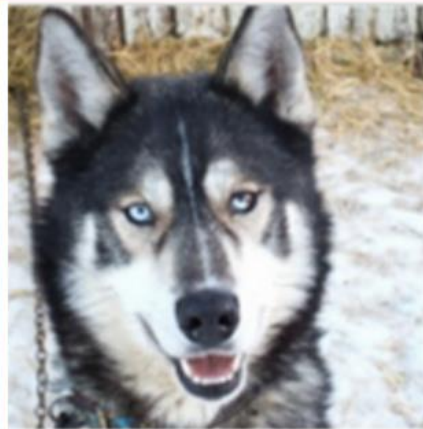

Predicted: **wolf**
True: **husky**

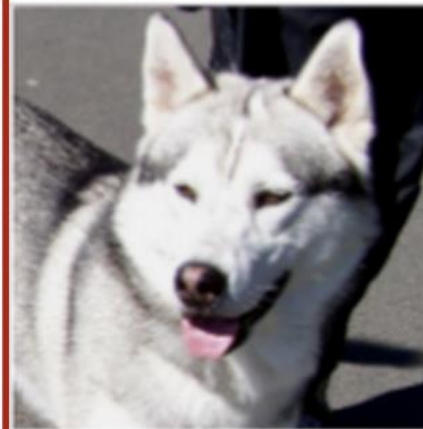

Predicted: **husky**
True: **husky**



Predicted: **wolf**
True: **wolf**



Predicted: **wolf**
True: **wolf**

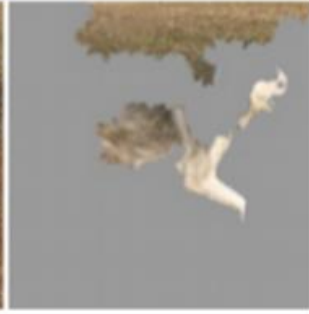

Predicted: **husky**
True: **husky**



Predicted: **wolf**
True: **wolf**

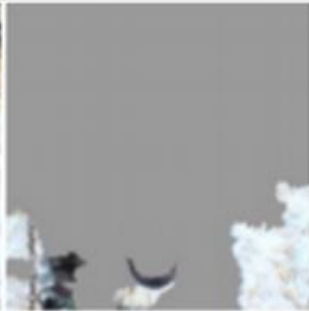
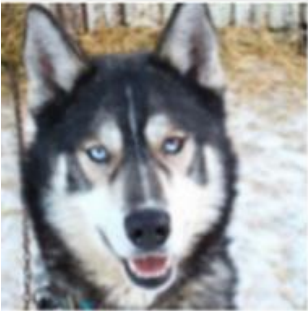

Predicted: **wolf**
True: **husky**

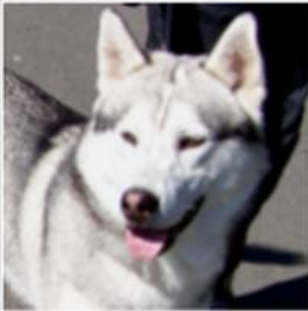

Predicted: **husky**
True: **husky**

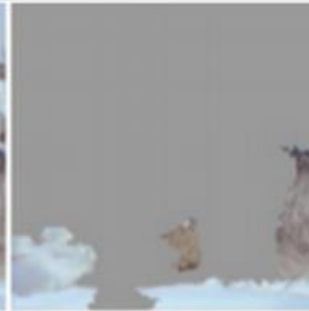

Predicted: **wolf**
True: **wolf**

The Need for Explainable AI

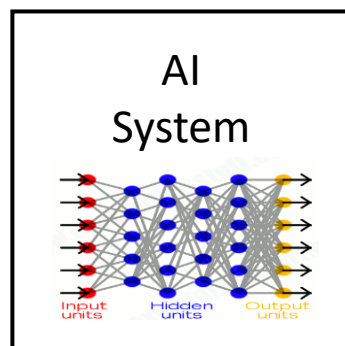

- We are entering a new age of AI applications
- Machine learning is the core technology
- Machine learning models are opaque, non-intuitive, and difficult for people to understand

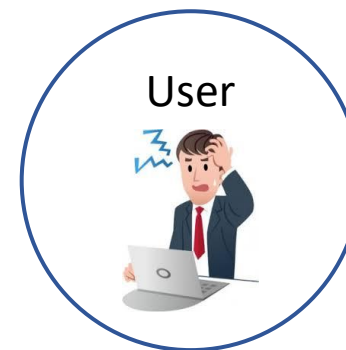

- Why did you do that?
- Why not something else?
- When do you succeed?
- When do you fail?
- When can I trust you?
- How do I correct an error?

- The current generation of AI systems offer tremendous benefits, but their effectiveness will be limited by the machine's inability to explain its decisions and actions to users.
- Explainable AI will be essential if users are to understand, appropriately trust, and effectively manage this incoming generation of artificially intelligent partners.

XAI Concept

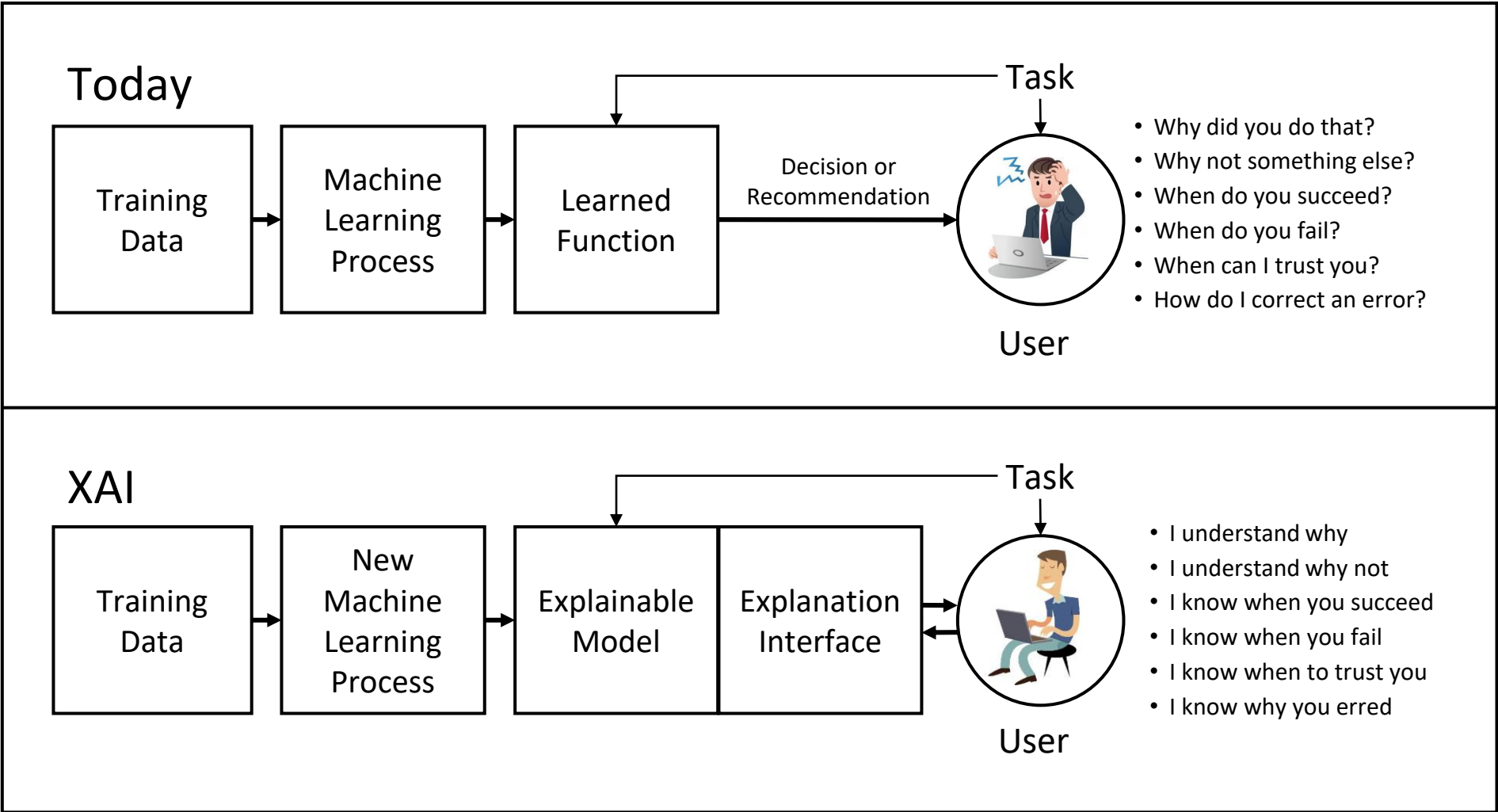

XAI Concept

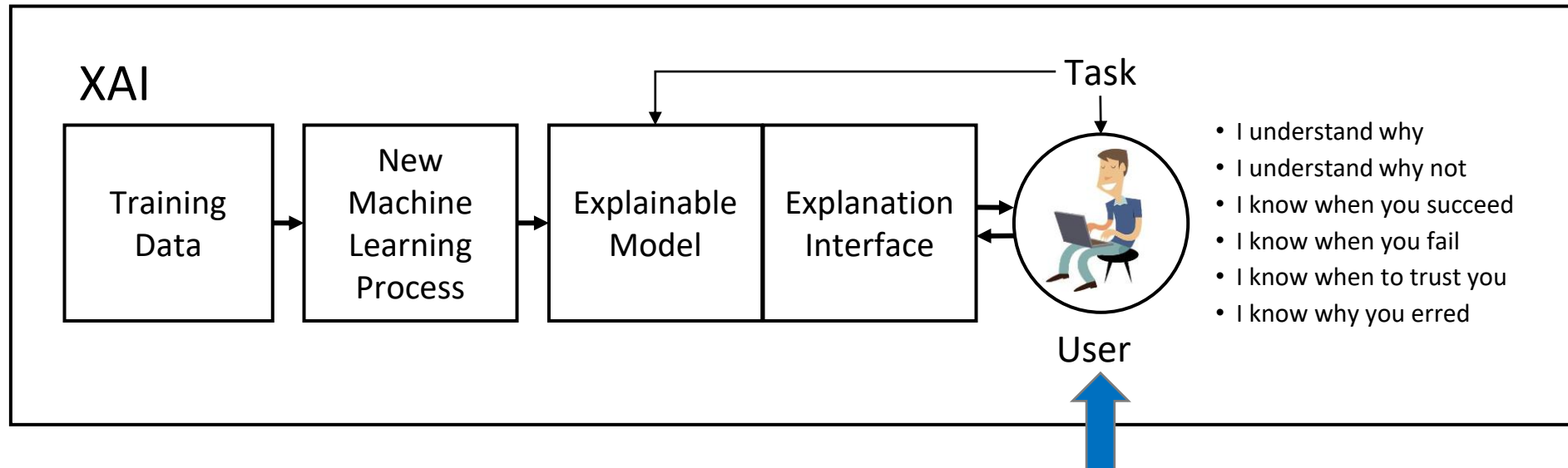

- **The target of XAI is an end user who:**
 - depends on decisions, recommendations, or actions of the system
 - needs to understand the rationale for the system's decisions to understand, appropriately trust, and effectively manage the system
- **The XAI concept is to:**
 - provide an explanation of individual decisions
 - enable understanding of overall strengths & weaknesses
 - convey an understanding of how the system will behave in the future
 - convey how to correct the system's mistakes (perhaps)